



The 4 backup generators power plant allows a common bus paralleling and a mains paralleling using both **GENSYS 2.0** and **MASTER 2.0**. Because of the important need of a reliable power supply on this site, the installation includes features such as:

- Medium voltage and low voltage paralleling on separate bus.
- Automatic start/stop sequence depending on load.
- Backup mode and security inhibition

More than all these options, it is also essential to reduce the blackout delays after a mains failure. In a normal application, the start and synchronization delay of the 4 generators before allowing the power to supply the

plant can reach 1 to 2 minutes, which is not acceptable on a hospital application.

In order to provide an adapted solution and to allow the power plant to deliver its full power within a short delay, CRE TECHNOLOGY has proposed a feature integrated as standard in all its **GENSYS 2.0** range: static paralleling.

Static paralleling aims at getting all the generators of the power plant synchronized and ready to provide full power within a short delay (less than 10s).

The method to achieve this function is a startup synchronization with a common excitation ramp when all engines are closed on busbar and running at nominal speed.

During the commissioning of this hospital, static paralleling synchronization was performed within a 7s delay during several tests, providing that this reliable feature fits all sites requiring a maximum power safety.

More than the rapidity of the synchronization, static paralleling can provide the magnetization of step up transformers which allows the use of smaller power cable sections.

It represents a significant economy on medium voltage applications, even on single generator applications with transformers.

For the same reasons, the **MASTER 2.0** also provides this option of transformers magnetization on black start operation.

APPLICATION



DETAILS OF APPLICATION

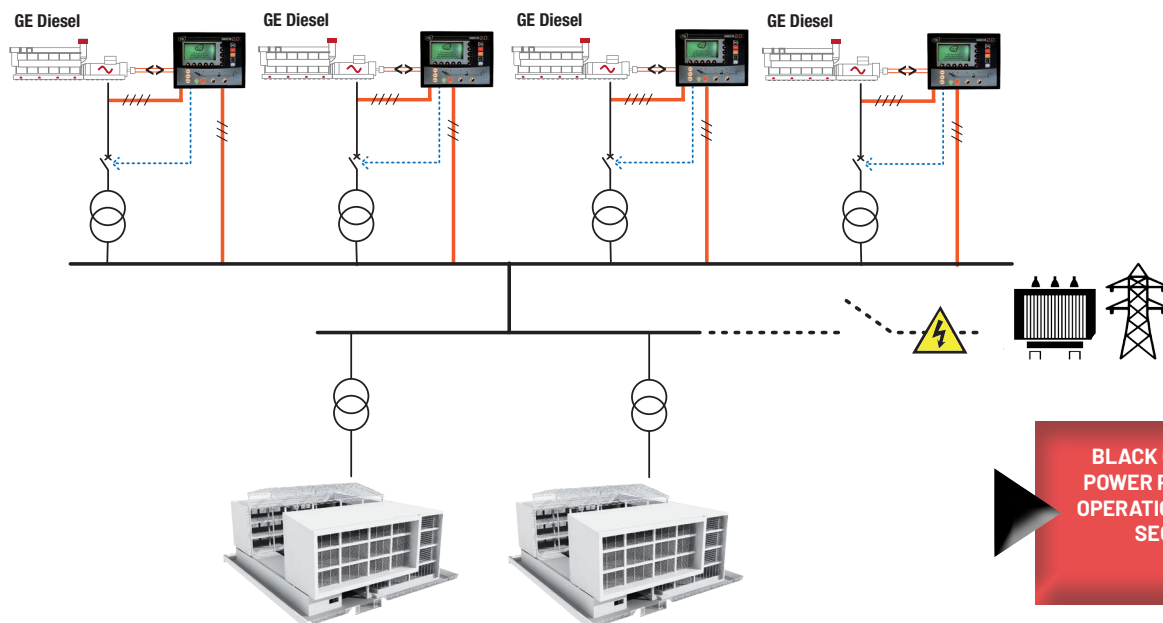



EXPERT IN GENERATOR SOLUTION

CRE TECHNOLOGY

130 allée Charles-Victor Naudin - Les templiers - Sophia Antipolis

06410 BIOT / FRANCE

Tél: +33 (0) 492 38 86 82

Fax: +33 (0) 492 38 86 83

info@cretechnology.com

STATIC PARALLELING HOSPITAL APPLICATION FRANCE_EN_A2018

