

CRE TECHNOLOGY offers 3 basic microprocessor modules 72 x 72 for generator control. These modules display all information on leds and 10A relay outputs.

- **MDM:** is a basic microprocessor controlled unit designed to start and stop the genset manually using the key switch and pushbuttons on the front panel.
- **MDA:** is a basic microprocessor controlled unit designed to start and stop the genset automatically on request of an external Remote Start signal.
- **MNS:** is a basic microprocessor controlled unit designed to monitor 3-phase mains voltages, send remote start commands to the genset, and manage changeover of both the generator and the mains contactors.

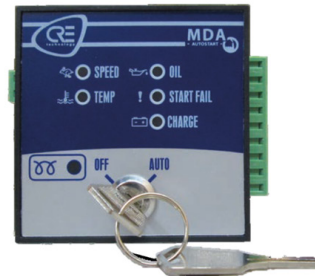

MDM MODULE
FRONT FACE KEYSWITCH



MDA MODULE
FRONT FACE KEYSWITCH



MNS MODULE
REAR FACE



Part numbers:

- A60Z3** -MDM module
- A60Y1** -MDA module
- A60W1** -MNS Module

Related products & Cables:

- A56-AMF-00** AMF Compact

FEATURES

▶ A SIMPLE PRODUCT FOR BASIC APPLICATIONS

- **MDM:** The manual start and stop sequences have been reduced to their simplest form. The front panel provides "RUN" and "OFF" positions, with a preheat button when required. The alarm LEDs show any engine fault condition: overspeed, underspeed, high engine temperature, low oil pressure, auxiliary shutdown.
- **MDA:** When the engine is running, the unit monitors fault conditions and shuts down the engine automatically if an alarm occurs. The alarms are identified by LEDs. On an OFF position, the module is de-energized and the remote start is disabled with no current consumption. The unit uses high current two part connectors for easy replacement.
- **MNS:** The functions have been reduced to the minimum. The front panel diagram provides information about the mains and generator power availability as well as contactor positions. The **MNS** continuously monitors the AC mains phase voltages. If at least one of the phase voltages goes outside set limits, it triggers a transfer cycle.

▶ ENERGIZE TO STOP CONTROL

- The **MDM** is also able to control 'Energize to Stop' engines. When the 'Energize to Stop' option is selected, the auxiliary relay output will be energized during the stop timer and the led associated with this condition will be turned on. The choice of engine type is made using a jumper switch.

- The **MDA** is also able to control 'Energize to Stop' engines. When the 'Energize to Stop' option is selected, the auxiliary relay output will be energized during the stop timer and the LED associated with this condition will be switched on. The selection of engine type is made by a jumper switch.

▶ COMPATIBILITY

- **MDM:** The limits for the correct generator frequency are 25 to 57 Hz when in 50Hz operation and 25 to 68Hz for 60Hz operation.
- **MDA:** The unit is able to operate with both 50 and 60 Hz systems. The selection is made with a jumper switch.
- **MNS:** The unit may be used with most commercially available or custom built engine control systems. The lower limit of the mains and genset voltages may be manually adjusted via the potentiometer found on the left hand side of the unit. The upper voltage limit is factory set. The unit uses two part connectors for easy replacement

▶ RELIABLE AND EASY TO USE

- The **MDM** is dedicated to basic applications which tolerate no extra costs or expensive hardware. The **MDM** has passed EMC and low voltage tests, and all units are 100% tested before delivery.
- The **MDA** is dedicated to basic applications which need no extra costs or expensive hardware. The **MDA** has passed EMC and low voltage tests, and all units are 100% tested before delivery.

- The **MNS** is dedicated to basic applications which allow no extra costs or expensive hardware. All CRE Technology products aim to provide the same level of satisfaction. The **MNS** has passed EMC and low voltage tests, and each unit is 100% tested before delivery.

▶ OPTIONS

- **MDM:** Engine control (without alternator).
- **MDA:** Preheat with activate to start and energize to stop without preheat.
- **MNS special test mode function:** it provides a TEST pushbutton allowing the genset to be tested without a mains failure. The Test mode can serve as Emergency Backup mode to keep the generator running and trigger a quick transfer in the event of a mains failure.

APPLICATIONS

Basic units are easy to use and made for small genset refit or manual backup system, there is no PC requires for settings.



SPECIFICATIONS

➤ MDM: CURRENT, VOLTAGE AND FREQUENCY

- **Alternator voltage:** 15 to 300 V_{AC}
- **Alternator frequency:** 50 or 60 Hz nominal.
- **Overspeed:** nominal frequency + 14% (+24% overshoot)
- **Underspeed:** 25Hz.
- **DC supply range:** 8 to 33 V_{DC}
- **Current consumption:** 80mA max. (Outputs open)
- **Charge fail threshold:** 6 V_{DC}
- **Charge excitation current:** via a 82 Ω resistor connected to the FUEL output.

➤ MDM: INPUTS, OUTPUTS

- **DC supply:** 12 or 24 V_{DC}, (+) and (-) terminals.
- **L1:** generator phase voltage.
- **Neutral:** generator neutral terminal.
- High temp switch, low oil pressure.
- **Aux:** spare fault input. A negative supply connected to this input will cause the engine to be stopped immediately and an alarm to be triggered (independent of the protection hold-off timer).
- **Charge:** this terminal will supply the excitation current and measure the voltage of the charge alternator.
- **Output:** Fuel solenoid: 10A@28V_{DC} / Start: 10A@28V_{DC} / Auxiliary: 10A@28V_{DC}

➤ MDA: CURRENT, VOLTAGE AND FREQUENCY

- **Alternator voltage:** 15 to 300 V_{AC}
- **Alternator frequency:** 50 or 60 Hz nominal.
- **Overspeed:** nominal frequency + 14% (+24% overshoot)

- **DC Supply Range:** 8 to 33 V_{DC}
- **Current consumption:** 80mA max. (Outputs open)
- **Charge fail threshold:** 6 V_{DC}
- **Charge excitation current:** via 82 Ω resistor connected to the FUEL output

➤ MDA: INPUTS, OUTPUTS

- **DC supply:** 12 or 24 VDC, (+) and (-) terminals.
- **L1:** generator phase voltage.
- **Neutral:** generator neutral terminal.
- **High temp switch/ Low oil pressure:** negative closing switch input.
- **Remote start:** a negative supply connected to this input will run the engine.
- **Charge:** connect the charge alternator's D+ output to this terminal. This terminal will supply the excitation current and measure the voltage of the charge alternator.
- **Output:** Fuel solenoid: 10A@28V_{DC} / Start: 10A@28V_{DC} / Auxiliary: 10A@28V_{DC}

➤ MNS: CURRENT, VOLTAGE AND FREQUENCY

- **DC supply:** 12 or 24 V_{DC}, (+) and (-) terminals.
- **R-S-T:** mains phase voltages.
- **MN:** mains neutral terminal.
- **G:** Generator phase voltage / GN: Generator neutral terminal.
- **Output:** Normally closed relay output connecting the phase-R voltage to the terminal. (10A@250V_{AC})

➤ MNS: INPUTS, OUTPUTS

- **Alternator Voltage:** 15-300 V_{AC} (Ph-N) / Mains

Voltage: 300 V_{AC} max (Ph-N)

- **DC supply range:** 9 to 33 V_{DC}
- **Current consumption:** 80mA max. (Outputs open).
- **Low Voltage Limit:** Adjustable from 70 to 270V_{AC}
- **High voltage Limit:** 320 V_{AC} Ph-N (fixed)

➤ MNS: GENERATOR CONTACTOR

Normally open relay output connecting the phase-G voltage to the terminal. (10A@250V_{AC})

➤ MNS: REMOTE START

Normally open engine start request relay output. Connects the battery positive to the terminal. (10A@28V_{DC})

➤ DIRECTIVES

- EMC & Low Voltage

➤ ENVIRONMENT

- **Operating temperature:** -20°C (-4°F) to 70 °C (158°F).
- **Storage temperature:** -30°C (-22°F) to 80 °C (176°F).
- **Maximum humidity:** 95% non-condensing.

➤ SIZE AND WEIGHT

- **Dimensions:** 72x72x38mm (WxHxD)
- **Panel cut-out dimensions:** 68x68 mm
- **Weight:** 140g (approx.)

WIRING DIAGRAM

**M
D
M**

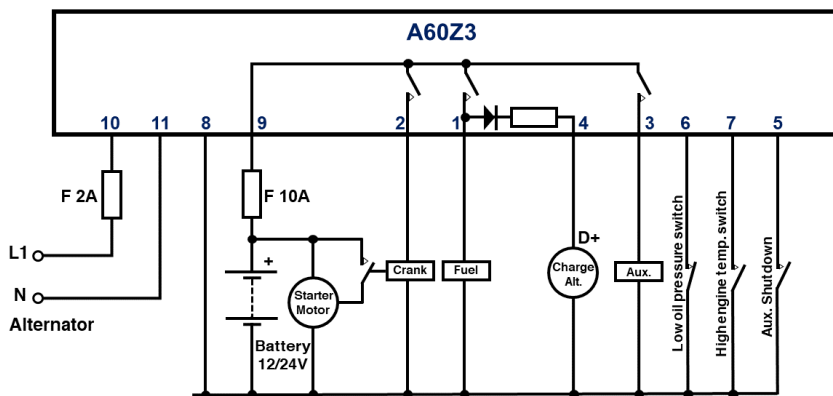

**M
D
A**

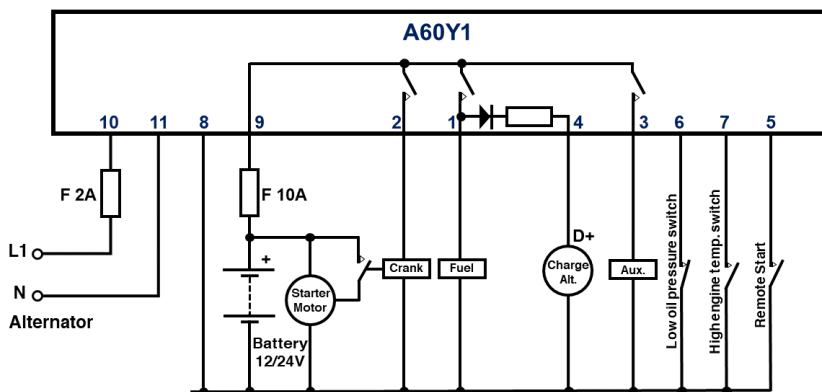

**M
N
S**

