

# MASTER 2.0



## All-in-one mains paralleling unit with integrated PLC

- Compact “all in one” module
- Fully compatible with GENSYS 2.0 and most analog lines modules
- Internal logic sequences, programmable by equations with the Easy PLC software
- Isolated ports: RS485, 2 CAN bus
- SD card reader, Ethernet
- All mains paralleling sequences management
- Large, multi-function graphic display
- Embedded web site



**The MASTER 2.0 is a power plant controller for gensets in parallel with one or several mains.**

**This “all-in-one” unit includes all necessary functions:**

- **Multi mains management**
- **Three phase mains failure detection**
- **Electrical protection**
- **Electrical parameters display**
- **Manual and automatic paralleling with mains (frequency, phase and voltage)**
- **kW power management with several modes:**
  - **No break change over with load transfer**
  - **Permanent paralleling in base load**
  - **Permanent paralleling in peak shaving mode**
- **Power factor control when paralleling with mains.**
- **Dyn11 capabilities (HV phase compensation)**
- **Analog control for all load sharing modules.**

### PROGRAMMABLE EQUATIONS

The MASTER 2.0 controller is a real PLC unit where equations and sequences can be programmed directly by the user with text editor software or Easy PLC software.

### INPUTS / OUTPUTS WITH NO LIMITS

The number of input/outputs that can be added is one of the most important on the market. Extension modules (DIN rail mounting) can be added on the CAN bus.

You can add both digital and analog inputs/outputs.

### MAINS AND POWER PLANT ELECTRICAL PARAMETERS

Not only the MASTER 2.0 parallels the power plant with mains, it also protects the power plant and measures electrical parameters.

### APPLICATIONS

- **Constant generating set power (base load) :**  
In this mode, the generating sets provide constant power. Mains power varies according to the load.
- **Constant mains power (peak sharing) :**  
In this mode, the mains power (imported or exported) remains constant. The generating sets vary their power according to the load.
- **Power plant control with several mains:**
  - 1 MASTER 2.0 per mains
  - No-break change-over with load transfer.
  - Transfer-switch unit control.

## WIRING EXAMPLES

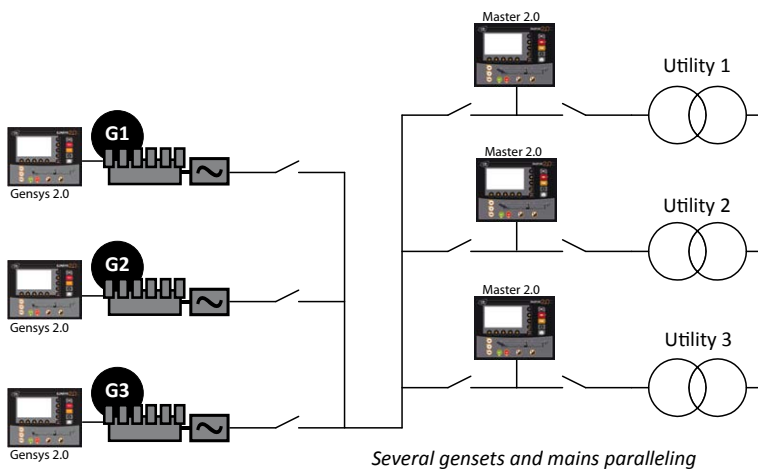
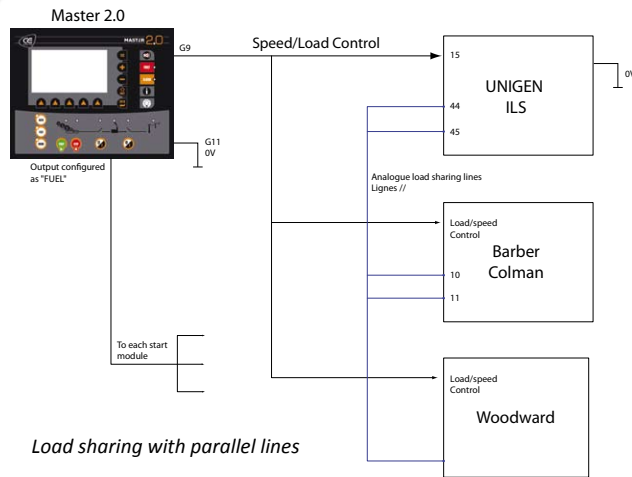

## EXTENSIONS

### With I/O external modules

A large range of modules are compatible with the MASTER 2.0 via CAN bus. You can add more than 250 analog and digital I/O:

- Analog inputs: PT100, 4-20mA, 0-10V, THK...
- Analog outputs: 4-20mA, 0-10V, PWM...
- Digital inputs
- Digital outputs

added value

**EQUATIONS :**  
Embed your knowledge!

MASTER 2.0 integrates a real PLC unit in which user equations and sequences can be written using a simple text editor or graphically designed using the Easy PLC software.



# MASTER 2.0



## FEATURES

- Power plant electrical parameters display:
  - Power plant overview
  - Generator state
  - Individual generator alarm
  - Phase-phase Voltage (3 phase RMS)
  - Phase-neutral Voltage (3 phase RMS)
  - Current (3 phase RMS)
  - Frequency
  - Active power (3 phase + total)
  - Reactive power (3 phase + total)
  - Power factor (3 phase + total)
  - Active power energy (kWh)
  - Reactive power energy (kVARh)
- Mains electrical parameters display:
  - Phase-phase voltage (3 phase RMS)
  - Phase-neutral voltage (3 phase RMS)
  - Current (3 phase RMS)
  - Frequency
  - Active power (3 phase + total)
  - Reactive power (3 phase + total)
  - Power factor (3 phase + total)
  - Active power energy (kWh)
  - Reactive power energy (kVARh)
- Manual and automatic frequency and phase synchronization (differential frequency meter + synchroscope available on screen).
- Manual and automatic voltage synchronization (differential voltmeter available on screen).
- Active power control (by CAN bus, up to 32 GENSYS 2.0/ Master 2.0 units).
- Power factor control (by CAN bus, up to 32 GENSYS 2.0/ MASTER 2.0 units).
- Power management with several mains.
- Phase sequence protection.
- Phase shift compensation (ie: Dyn11).

- Short-circuit protection.
- Generator electrical protections: <F, >F, <U, >U, >I, >In, >P, <P, <-P, >Q, <Q, <-Q
- Mains electrical protections (option) : <F, >F, <U, >U, >P, <P, <-P, >Q, <Q, <-Q, phase shift, df/dt.
- The last 50 alarms and last 50 faults are recorded in non volatile memory.

## CHARACTERISTICS

### Current, voltage and frequency

- DC voltage power supply input: 9 to 40V<sub>DC</sub>, 750mA at 12V<sub>DC</sub> and 400mA at 24V<sub>DC</sub>.
- AC voltage inputs: 100 to 480V<sub>AC</sub>, 100mA max. Neutral terminal does not need to be connected.
- AC current inputs: 0 to 5A, 1VA. Each phase is isolated from the others.
- AC current overload: 15A during 10s.
- Frequency measurement: 45 to 70 Hz – 15V<sub>AC</sub> minimum between phase and neutral.
- Digital inputs: NO or NC to ground.
- Emergency stop input: normally closed, 24V.
- Relay outputs: 5A. The 24V is provided via the emergency push button.
- Relay outputs (breakers): 5A, 230V<sub>AC</sub> max. NO + NC available.
- Transistor outputs: 350mA, over-current protected.

### Inputs and outputs

- 2 analog inputs: 0 to 400 Ω. Calibration is configurable.
- 2 analog inputs (spare 1 and spare 2): 0 to 10kΩ. Calibration is configurable.
- Analog input (+/-20mA or +/-10V): 50 Ω (current) or 20 KΩ (voltage).
- Analog output between +/- 10 V<sub>DC</sub>

## Ports

- Isolated communication ports are available:
  - RS485 for Modbus RTU (read and write)/ male Sub-D 9 pins 120 Ω resistors selected by micro-switch.
  - CAN bus for inter-GENSYS/ MASTER 2.0/GENSYS 2.0 COREconnection: male Sub-D 9 pins 120 Ω resistors selected by micro-switch
  - CAN bus dedicated to options I/O extensions: male Sub-D 9 pins 120 Ω resistors selected by micro-switch
  - Ethernet: PC communication/ Modbus TCP
  - SD card reader

## Environment

- Operating temperature: 0°C to +55°C
- Storage temperature: -30 to +70°C
- Humidity: 5 to 95%. Circuits tropicalization for normal operation in humid conditions. Front panel: IP65 protection. Rear panel: IP20 protection.

## Size and weight

- Size: 248x197x57mm (9.76x7.76x2.24in)
- Panel cut out: 228x177 mm (8.98x6.97 in)
- Mounting: functions in any position, but visibility of the display should be taken into account.
- Weight: 1.9kg (4.2lb)

## Certifications

- European union directives: EN 50081-2, EN 50082-2, 73/23EEC

**Other**

- LCD characteristics: 114x64mm, 60 cd/m<sup>2</sup> backlight, 3 character sizes.
- Terminals: 2 piece connectors, 2,5mm<sup>2</sup>.
- Standard languages: English, Spanish, French, Italian
- Other custom languages: downlodable on request

**CABLES AND CONNECTORS**

- A53W1: Master 2.0 to PC cable - USB/USB - 3m.
- A40W8: CAN@ inter GENSYS 2.0 / MASTER 2.0 cable for 2 generators - DB9/DB9 - 7m.
- A40W2: CAN@ inter GENSYS 2.0 / MASTER 2.0 cable for more than 2 generators or CANopen@ I/O modules - DB9/free wires - 7m.
- A40W3: DB9/Terminals connector to be used with more than 2 generators for double connection (with screws).
- A40W4: communication cable (RS485, CAN, RS232) – per meter.

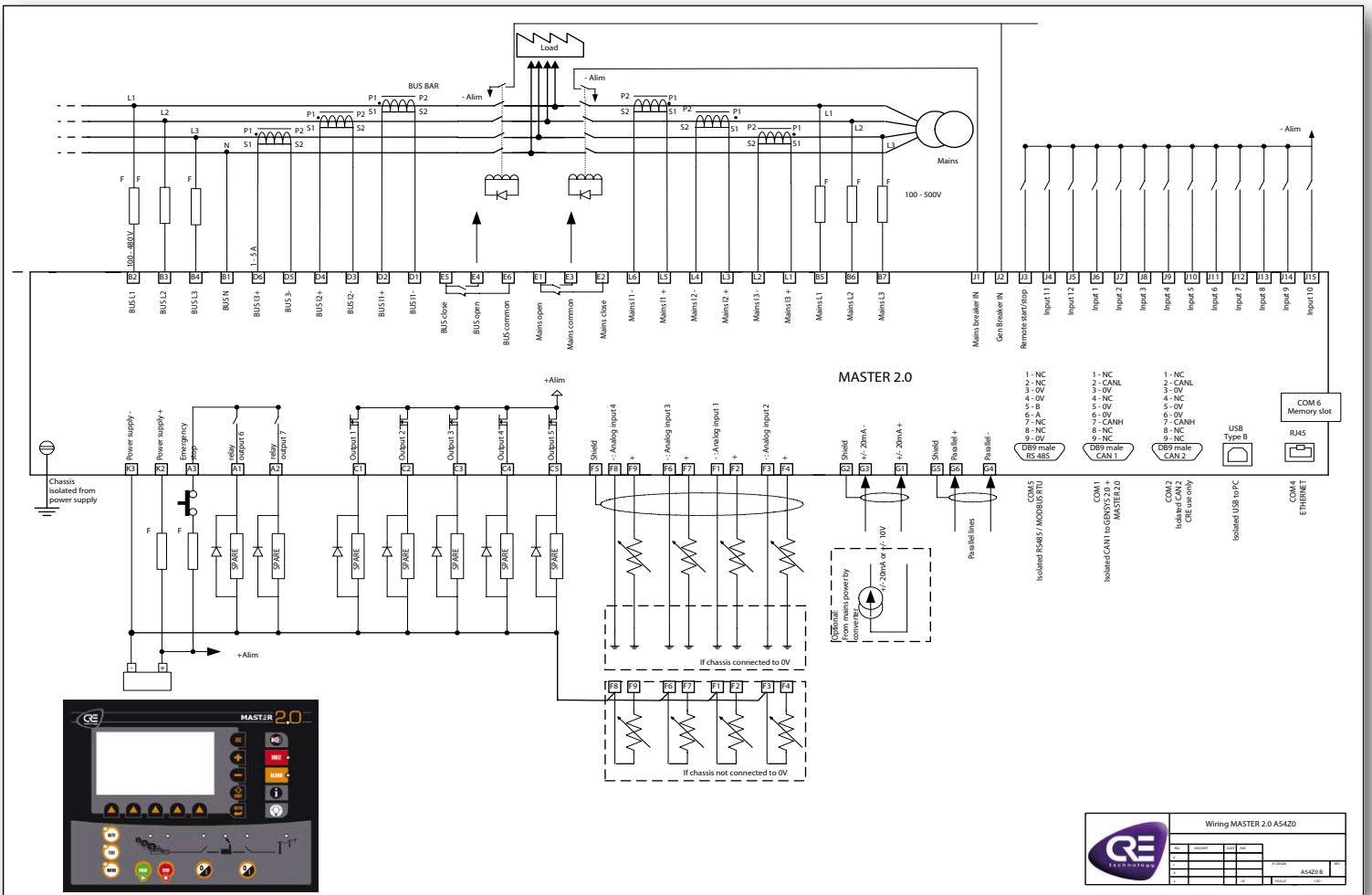

**PART NUMBER**  
A5420

**SOFTWARE**  
CRE Config / Easy PLC

**CABLE**  
A53W1

**ASSOCIATED PRODUCTS**  
Reduced: CPA  
Complementary: GENSYS 2.0