

Synchronization and load sharing module Technical documentation

CRE technology believes that all information provided herein is correct and reliable and reserves the right to update at any time. CRE Technology does not assume any responsibility for its use unless otherwise expressly undertaken.

CRE technology
Allée Charles-Victor Naudin - Zone des Templiers - Sophia Antipolis
06410 BIOT - FRANCE
Téléphone : + 33 (0)4.92.38.86.82 - Fax : + 33 (0)4.92.38.86.83
www.cretechnology.com info@cretechnology.com
SARL au Capital de 300.000 Euros
RCS Antibes : 7488 625 000 15 - N°TVA FR54 488 625 583



Read this entire manual and all other publications pertaining to the work to be performed before installing, operating, or servicing this equipment. Practice all plant and safety instructions and precautions. Failure to follow instructions can cause personal injury and/or property damage. Contact your CRE dealer for course training.

History:

VERSION	DATE	MODIFICATION
A	initial document	Initial document
B	March 2007	New PCB and Embedded software
C	November 2007	Administrative update
D	December 2008	Neutral in wiring diagram (three phase with neutral)
G	December 2009	MODBUS modification
H	February 2010	Connection to EFC speed regulator
I	May 2010	Firmware v1.28 : <ul style="list-style-type: none">• 500Hz PWM speed output.• MODBUS Read/Write functions.• External speed potentiometer features.• External synchronization input features.
J	February 2011	Commissioning tips for small generating sets (below 200kW). Description of the automatic load/unload feature (using CAN bus load sharing).

Documentation List:

- A51Z090004 : Technical documentation for UNIGEN *PLUS* and Industrial UNIGEN.
- A51Z190104 : Application note : GCR/UNIGEN *PLUS*, wiring mains synchronisation.
- A51Z090100 : Application note : Generating set auto synchroniser and load sharer.
- A51Z190101 : Application note : Load shedding.
- A51Z190102 : Application note : Paralleling lines wiring for Carantec/UNIGEN *PLUS*.
- A51Z190103 : Application note : Replacement of a Pow-R-Con 'DYN2-94026' by a UNIGEN *PLUS*.
- A51Z180006 : Application note : Procedure to download the complete firmware of a UNIGEN *PLUS*.
- A51Z290001 : Application note : Moving generators.
- A51Z090202 : Application pictures.
- A51Z090030 : Complete variable list with label, units and limits.

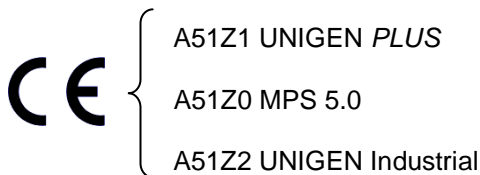

Contents

<i>History:</i>	2
<i>Documentation List:</i>	2
1. <u>Overview</u>	4
1.1. <u>UNIGEN front cover</u>	4
1.2. <u>Global functions</u>	5
2. <u>Features</u>	6
2.1. <u>Synch check relay</u>	6
2.2. <u>Reverse kW relay</u>	7
2.3. <u>kW Indicator</u>	7
2.4. <u>Remote speed control input</u>	7
2.5. <u>PWM 500Hz (A51M141 modules only)</u>	8
2.6. <u>Isochronous load sharing (UNIGEN PLUS) using parallel lines</u>	8
2.7. <u>CAN load sharing</u>	9
2.7.1. <u>Plug'n'play CAN protocol</u>	9
2.7.2. <u>Automatic load/unload request</u>	9
2.8. <u>Load sharing</u>	10
2.8.1. <u>Ramps</u>	10
2.8.2. <u>Automatic TRIP OUT</u>	10
2.8.3. <u>Manual load/unload request</u>	11
2.9. <u>DROOP load sharing</u>	11
2.10. <u>COMMAND MODE (UNIGEN PLUS)</u>	11
2.11. <u>MAINS PARALLELED (UNIGEN PLUS)</u>	11
2.12. <u>Modbus (UNIGEN PLUS)</u>	13
3. <u>Settings</u>	15
4. <u>Display</u>	16
5. <u>Terminals</u>	17
5.1. <u>Terminals description</u>	17
5.2. <u>Wiring diagram</u>	19
5.3. <u>Connection specifications</u>	19
6. <u>Risk</u>	20
6.1. <u>Caution</u>	20
6.1.1. <u>Grounding:</u>	20
6.1.2. <u>Wiring rules:</u>	20
6.1.3. <u>Vibrations:</u>	20
6.2. <u>Power plant start-up/Commissioning</u>	21
<u>Environment</u>	24
<u>Dimensions</u>	24

1. Overview

1.1. UNIGEN front cover

Each terminals of the industrial UNIGEN are also available on UNIGEN PLUS.

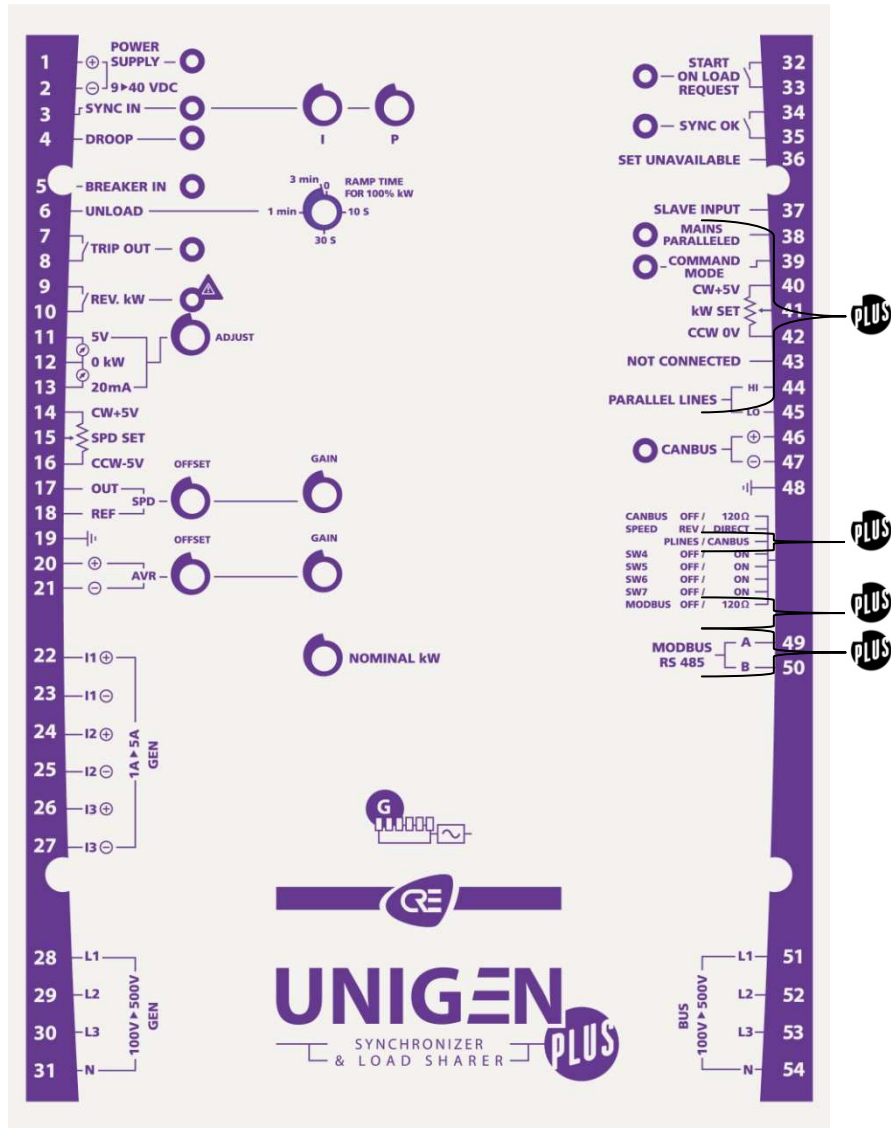

Ⓢ Only for UNIGEN PLUS: this symbol is used in technical documentation to indicate UNIGEN PLUS special features.

1.2. Global functions

The main functions performed by the UNIGEN are followings :

- Automatic and Manual synchronization (cf. SW5 et SW6 configuration).
- Active load sharing in **isochronous**, **droop** mode or **Command** mode (UNIGEN *PLUS* only).
- Reactive load sharing in **isochronous** voltage, **droop** mode or **power factor fixed** (UNIGEN *PLUS* only).
- Compatibility with all speed governors (cf. SW2 configuration) and AVR on the market.
- Remote speed control by potentiometer (cf. SW7 configuration).
- Internal synch check relays, useful for auto and manual synchronization.
- Phase sequence protection.
- Load sharing with CAN plug and play (cf. SW1 configuration) or with paralleling lines (UNIGEN *PLUS* only, cf. SW3 configuration).
- Automatic load/unload.
- Reverse kW relays.
- 2 analogue outputs (0...5V et 0...20mA/4...20mA) for kW meter (cf. SW4 configuration).
- MODBUS RTU on serial port RS485 (UNIGEN *PLUS* only, cf. SW8 configuration).
- Command mode (Unigen Plus only).
- Mains Paralleled (UNIGEN *PLUS* only).

2. Features

2.1. Synch check relay

SYNC_OK output (terminals 34/35) permit the coupling of generators when all following conditions are correct:

- Voltage of generator and bus bar within a 15 - 130% window from nominal voltage (500V).
- Voltage difference between generator and bus bar, < 10%.
- Frequency of generator and bus bar within a 30 - 130% window from nominal frequency.
- Phase Angle difference between generator and bus bar. < +/- 10°.
- Frequency difference between generator and bus bar, < 0.01Hz.
- Phase sequence correct.

SW5 switch allow or not the coupling when **SYNC_IN** logical input (terminal 3) is active.

SW6 switch allow or not the coupling on *dead busbar*.

SYNC_OK relay behave like on the following board:

Logical inputs		Configuration		Electrical conditions		Relay	
BREAKER_IN (Terminal 5)	SYNC_IN (Terminal 3)	SW6 Dead BusBar	SW5 Synchronization (manual/auto)	Deadbus (No voltage on bus)	$\Delta\phi$, ΔHz , ΔV and phase sequence	SYNCH_OK (Terminals 34/35)	
Inactive (not connected)	Active (connected to 0V _{DC})	OFF	X	X	NOK	open	
		X	X	NO	OK	close	
		ON	X	YES	NOK	close	
		ON	X	NO	NOK	open	
	Inactive (not connected)	Inactive (not connected)	X	OFF	X	X	open
			OFF	ON	X	NOK	open
			X	ON	NO	OK	close
			ON	ON	YES	NOK	close
			ON	ON	NO	NOK	open
			ON	ON	NO	NOK	open

X: No matter.

NOTE :

Since firmware v1.28, **SYNC_IN** input is activated only if voltages (Genset and BusBar/Mains) are greater than 80% of nominal frequency. This setting can be changed using parameter E01226.

At start, on deadbus, there is a delay before closing the '**SYNC OK**' relay (E01033, default value is 3.0s).

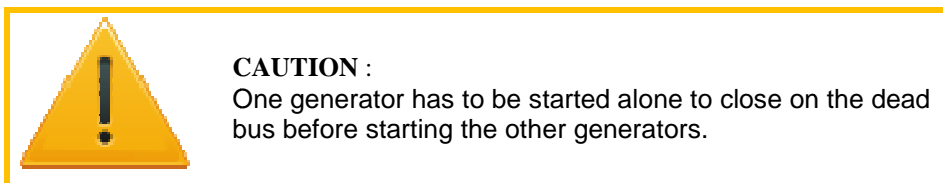

The '**SYNC OK**' green LED confirms the activation of the relay:

- LED ON = contact closed.
- LED OFF = contact open.

2.2. Reverse kW relay

UNIGEN includes a reverse kW relays, terminal 9 & 10. This relay output closes when the kW of the generator is below -5% of the nominal kW during more than 20 seconds.

The 'REV. kW' red LED confirms the activation of the relay:

- LED ON = contact closed.
- LED OFF = contact open.

2.3. kW Indicator

UNIGEN has two analogue outputs for kW indicator on terminals 11, 12 and 13. These outputs allow the display of active power (kW).

Outputs are between 0-5V_{DC}, 0-20mA or 4-20mA depending on SW4 configuration. A multi-turn potentiometer allows the calibration of the output to adapt it to your indicator.

2.4. Remote speed control input

UNIGEN includes a remote speed control input on terminals 14, 15 and 16. This input is provided for connecting an external potentiometer (5kΩ). The mid point of those potentiometers (5 turns for a 10 turns potentiometer) will generate a 0V signal to the cursor input and will not generate any speed deviation.

The potentiometer is taken into account depending on switch SW7:

- OFF position, potentiometer is always read by UNIGEN.
- ON position, potentiometer value is set to zero when generator breaker is closed (BREAKER_IN logical input active), normally read when generator breaker is open.

Maximal deviation speed + / - 3.00Hz (recommended range for output speed setting):

- +5V applied on cursor input will increase the speed of + 3.00Hz.
- -5V applied on cursor input will decrease the speed of -3.00Hz.

This input can also be used as 0-5V_{DC} for a master PLC control. In this case the nominal speed have to be adjusted with 2.5V_{DC} applied on cursor input.

EFC Cummins connection:

Due to a big sensitivity of Cummins EFC input speed, following wiring must be done.

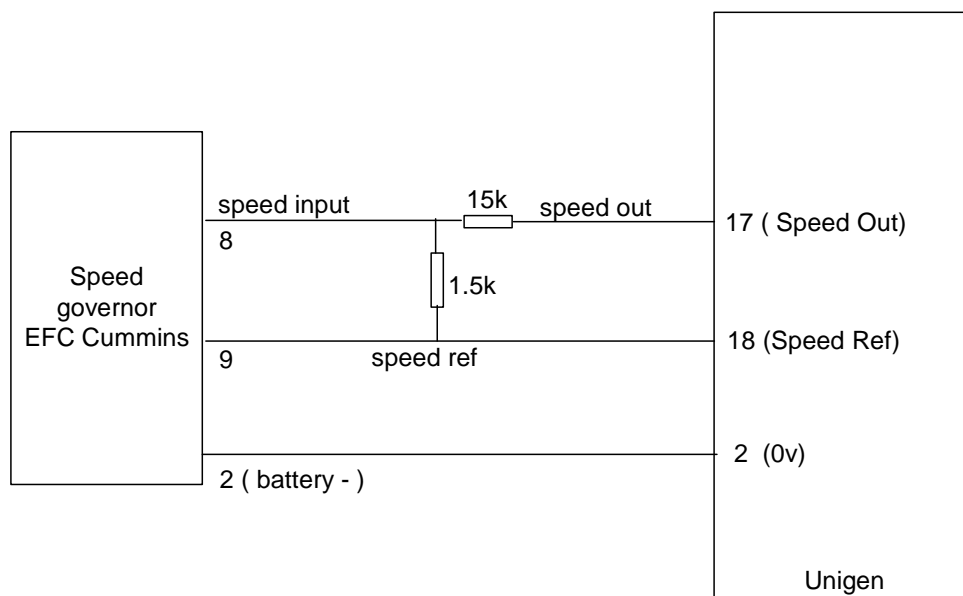

2.5. PWM 500Hz (A51M141 modules only)

UNIGEN *PLUS* offering PWM output features are identified with a modification label (A51M141). This option must be specified when ordering parts from your dealer.

Connection to the speed regulator must be done as shown below:

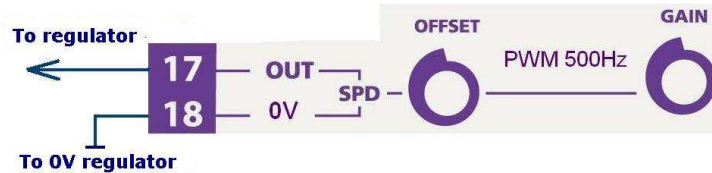

The output is protected against short-circuit to 0V. The PWM adjustment is done with the OFFSET and GAIN potentiometers of the speed output. Picture below shows the behaviour of the potentiometers on the output signal.

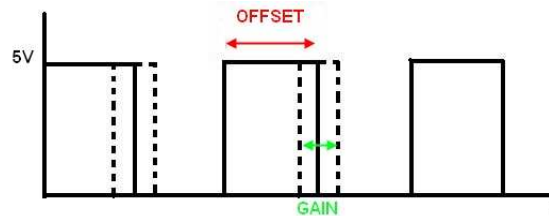

2.6. Isochronous load sharing (UNIGEN PLUS) using parallel lines

When 'DROOP' (terminal 4) input is opened and switch SW3 (plines/canbus) is on plines position (OFF), UNIGEN *PLUS* is set to isochronous load sharing mode, it compares its power with the level of the paralleling lines and generates an output signal to the speed governor to adjust its power.

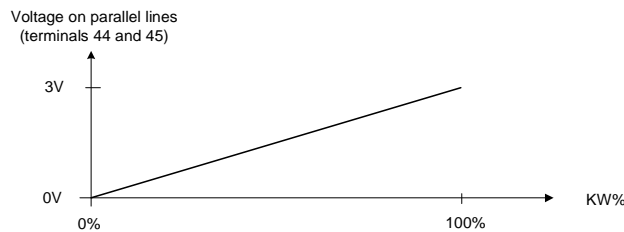

2.7. CAN load sharing

When 'DROOP' (terminal 4) input is opened and switch SW3 (plines/canbus) is on canbus (ON for UNIGEN *PLUS*), UNIGEN is in isochronous load sharing mode. The load setpoint will be calculated via the CAN connection.

Up to 8 UNIGEN modules can be connected via CAN bus.

The CAN bus needs terminal resistors at each end of the bus. Switch SW1 (CAN bus OFF/120Ω) to ON on the first and last UNIGEN modules. SW1 should be switched OFF on the other UNIGEN.

2.7.1. Plug'n'play CAN protocol

As soon as several UNIGEN are connected together through CAN bus, they choose automatically a generator number different from each other. They are able to share the load without any settings. If one UNIGEN disappears from the CAN, it is no longer taken under account by the others, and they continue to share the load isochronously.

The rules of the Plug'n'play CAN protocol are described below:

- UNIGEN must receive information on the availability of the GE. (Input SET_UNAVAILABLE). If this information is set to 0 then the UNIGEN will not participate to the negotiations.
- A generator is considered as slave when the **SLAVE INPUT** input is connected to 0V.
- At least one UNIGEN must be configured as master (**SLAVE INPUT** not selected).
- At power up, all UNIGEN connected to the CAN bus will be automatically attributed a set number (1, 2, 3...) according to the power supply sequence of the UNIGEN.
- At power up, all UNIGEN are fully operational during 2mn (No stop negotiation), then the automatic load/unload mode starts.

2.7.2. Automatic load/unload request

If the power plant load goes below 20% of the nominal power during more than 2 minutes, stop negotiations begin to elect one of the slave generators to stop.

If the power plant load goes above 70% of the nominal power of the power plant during 10 seconds, start negotiations begin to elect one of the slave generators to start.

If the load is between 20% and 70% of the nominal power than the actual number of generators on the bus bars will not change until 20% or 70% threshold is reached.

N.B: Both 20% and 70% thresholds are parameters that can be modified using a PC.

The 'START ON LOAD REQUEST' relay output can be used to start and stop the slave generators depending on the load request.

The 'START ON LOAD REQUEST' green LED confirms the activation of the relay:

- LED ON = contact closed.
- LED OFF = contact open.

'SET UNAVAILABLE' input:

- If UNIGEN is stopped and its **SET UNAVAILABLE** input is activated it will inhibit the start ('START ON LOAD REQUEST' relay kept open and 'TRIP OUT' relay closed) in case of the load request.



CAUTION:

If UNIGEN is running and on the bus bar, as soon as 'SET UNAVAILABLE' is closed the 'TRIP OUT' relay is activated (closed) to open the breaker of the generator.

Load shedding inhibition:

- Don't connect the 'START ON LOAD REQUEST' relay: the load shedding will not have any influences.
- In droop mode the load shedding is inhibited.

'START ON LOAD REQUEST' relay behaviour is described in the schematic below:

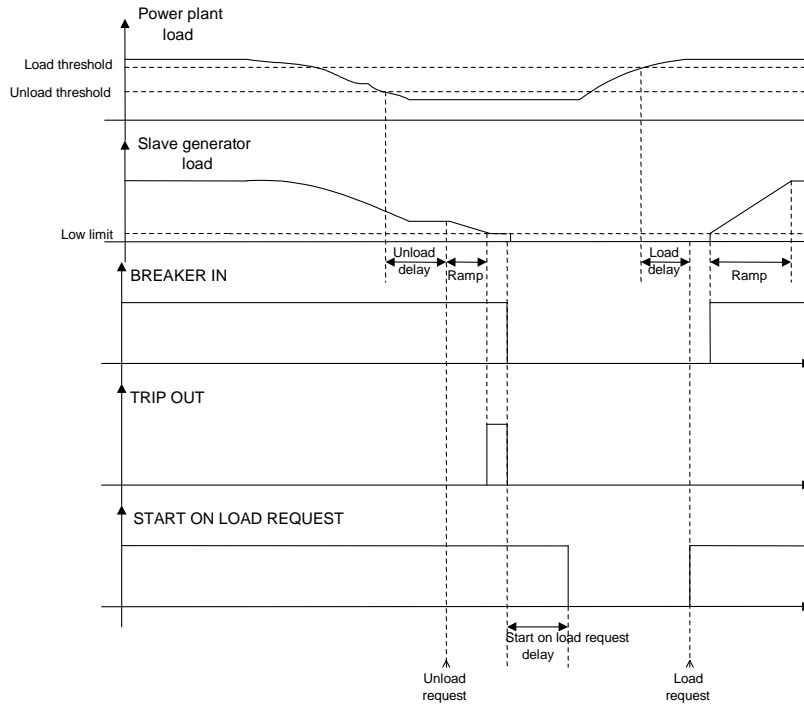

Note: at start up, 'START ON LOAD REQUEST' relay is closed. All generators are started because it is impossible to know the level of load before start.

2.8. Load sharing

2.8.1. Ramps

Ramp sequences:

- The first generator on the bus bars takes immediately the load with no ramp.
- The other generator load ramp stops when generators reach the load setpoint (average power plant load).
- The unload ramp stops when the power reach 5% of its nominal power.

Load and Unload ramp rates are using the same potentiometer. The single turn potentiometer named 'RAMP TIME' adjusts the ramp time from 0 seconds to 180 seconds. This setting is the time to transfer 100% of the nominal power.

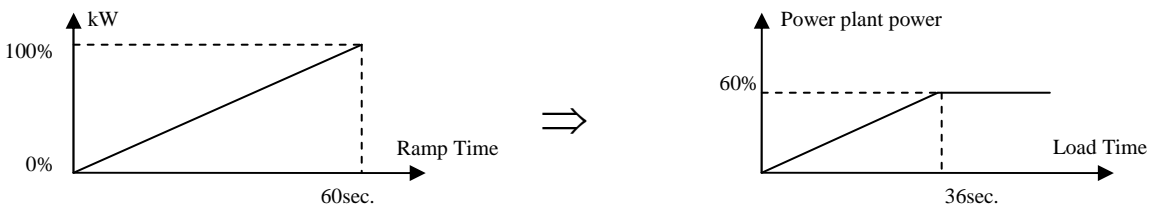

2.8.2. Automatic TRIP OUT

'TRIP OUT' relay (terminals 7 and 8) is used to open the breaker once the unload ramp is finished. The relay is closed when the kW of the generator which is unloading reaches 5% of the nominal kW.

The 'TRIP OUT' green LED confirms the activation of the relay:

- LED ON = contact close.
- LED OFF = contact open.

2.8.3. Manual load/unload request

The Load /Unload ramps are managed by the 'UNLOAD' input (terminal 6):

- 'UNLOAD' (terminal 6) input disconnected = when the breaker closes, the load ramp starts immediately.
- 'UNLOAD' (terminal 6) input connected to 0v = the generator starts an unload ramp.

2.9. DROOP load sharing

When DROOP (terminal 4) input is connected to 0 V_{DC}, UNIGEN is in Super droop mode. In this mode the load sharing is managed between 50.50Hz (0% load) and 50.00Hz (100% load).

For this specific droop, it is not needed to set precisely the engine speed, and any connections are required between each UNIGEN, even the 0V.

kW and kVAR load sharing are managed with droop.

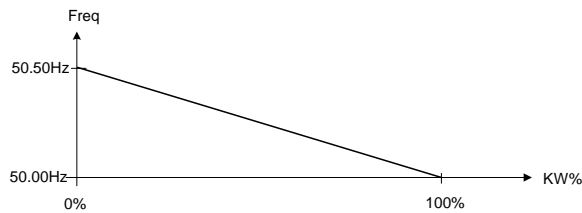

2.10. COMMAND MODE (UNIGEN PLUS)

When the following conditions are met:

1. 'DROOP' input is opened (terminal 4 not connected).
2. 'COMMAND MODE' input is closed (terminal 39 connected to the 0VDC).
3. Generator breaker is closed (terminal 5 connected to the 0VDC).

Then the UNIGEN Plus is in '**Command mode**'. The setpoint load is fixed via the remote potentiometer of kW set point (terminals 40/41/42) and the power factor is fixed to 0.95 using parameter E11020.

The low limit of the potentiometer is 5% and the high limit is 110% of nominal kW. Behaviour of kW setpoint (potentiometer) is described on schematic below:

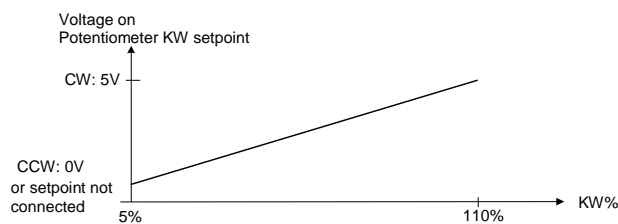

COMMAND mode is described in the second schematic shown on chapter 'MAINS PARALLELED'.

2.11. MAINS PARALLELED (UNIGEN PLUS)

When the following conditions are met:

1. 'DROOP' input is opened (terminal 4 not connected).
2. 'COMMAND MODE' input is opened (terminal 39 not connected).
3. 'MAINS PARALLELED' input is closed (terminal 38 connected to the 0V_{DC}).
4. Generator breaker is closed (terminal 5 connected to the 0V_{DC}).

Then UNIGEN PLUS is in 'Mains paralleled' mode. The setpoint load is fixed by the paralleling lines (terminals 44/45) (coming from the GCR for example) and the power factor is fixed at 0.95 by the parameter E11020.

A 0V in paralleled lines (terminals 44/45) is that the generator takes 0% of load, a 3V in paralleled lines is that the generator takes 100% of load.

Behaviour of kW setpoint (paralleling lines) is described on schematic below:

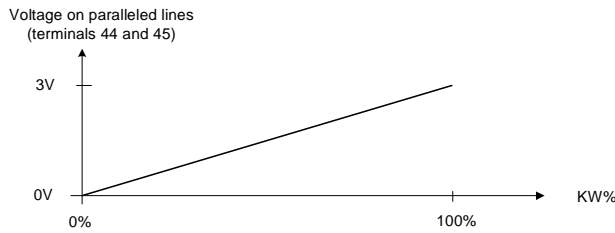

COMMAND mode and MAINS PARALLELED active power behaviour are described in the schematic below:

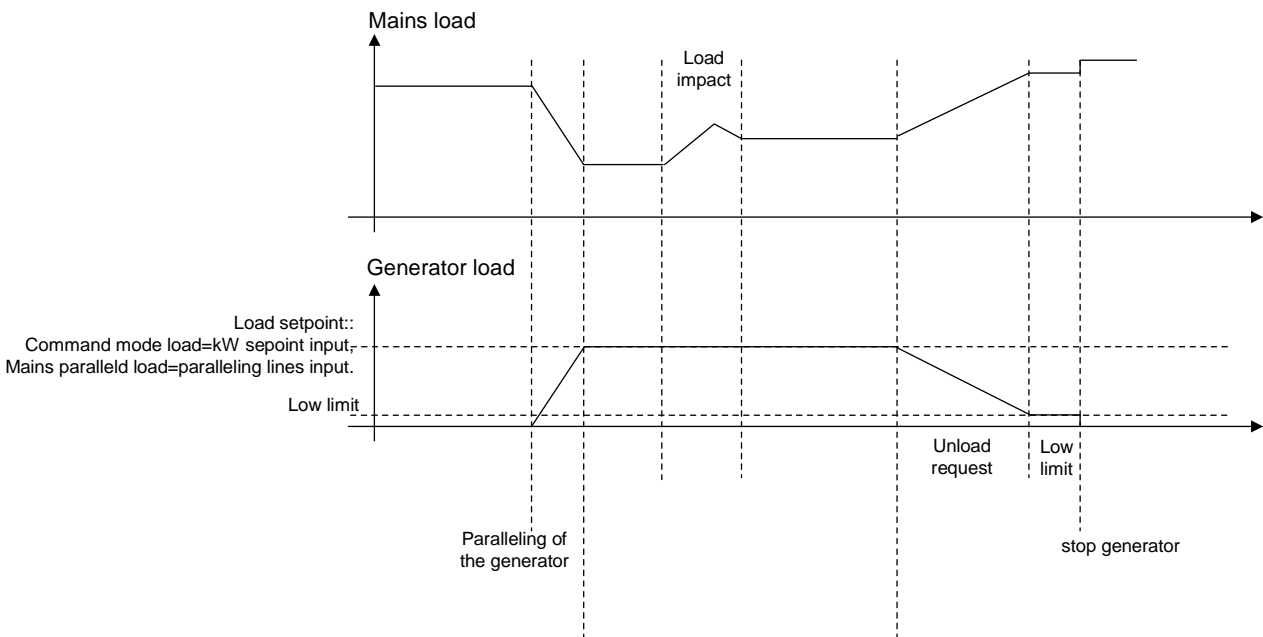

Active power set point behaviour in different mode is described in the following table:

Terminal 6 'unload'	Terminal 5 'breaker in'	Terminal 4 'droop'	Terminal 38 'mains paralleled'	Terminal 39 'command mode'	SW3 plines / canbus	Mode	kW management
X	open	X	X	X	X	waiting	not
open	close	close	X	X	X	droop	frequency
open	close	open	open	open	OFF	load sharing	paralleling lines (T44-45)
open	close	open	open	open	ON	load sharing	Can bus (T46-47)
open	close	open	X	close	X	COMMAND mode	kW set point (T 41)
open	close	open	close	open	X	Mains paralleled	paralleling lines (T 44-45)
open	close	open	X	X	X	Unload	Ramp time pot. (RV3)

Close = connected to 0V_{DC}.

Open = not connected.

🔴 = Pink cells concern UNIGEN PLUS only.

2.12. Modbus (UNIGEN PLUS)

Switch SW8 (Modbus OFF/120Ω) to ON (120Ω resistor) when the UNIGEN PLUS is used on end of line. All the logical and analogue input/output values and all the other parameters which appear in the UNIGEN PLUS menus can be read by the serial port RS485 terminals 49A and 50B (2 wires). UNIGEN PLUS behaves as a MODBUS slave device.

Support of MODBUS RTU by the UNIGEN PLUS is performed using the following parameters:

- Communication speed: 4800, 9600 and 19200 (default: 19200).
- Number of bits by character: 8.
- Number of parity bits: 0.
- Number of stop bits: 1.
- RTU address: 1 to 569B.
- Supported function: 04 (analogue reading) and 03 (registers reading) and 06 (registers writing).
- The RTU address of the variables is the same than their number plus 1, converted in hexadecimal. For example variable E00110 (Mains break input), its RTU address is 006Fh (111). See the A51Z090030.xls file to know the variable number.

MODBUS registers writing meets the following rules:

- Ex0xxx measures are "Read only".
- Ex1xxx parameters are factory set to "Read only". It is possible to switch them to "Read/write" using the embedded Web site. To do so it is necessary to connect to UNIGEN with a laptop in level 2 (distributor password). Go to **Configuration/Modification by variable nb** page, enter the parameter that you want to change, and then in the « Writing by modbus/PLC » box, choose « allow » and validate. Go to **System/Flash all parameters** and press « FLASH it » red button to save parameters (Otherwise changes are lost when UNIGEN is switched off).
- Variables Ex2xxx can be written using MODBUS without restriction.

Reading example: Slave N°1, addresses from 001h to 003h included (3 registers)

Request:

Fields	Value (hex)
Slave address	01
Function	04
MSB start address	00
LSB start address	01
MSB number of registers	00
LSB number of registers	03
CRC16	--

Response:

Fields	Value (hex)
Slave address	01
Function	04
Number of bytes	06 (3 registers * 2 bytes per register)
1st byte (MSB of 1st reg.)	xx
2nd byte (LSB of 1st reg.)	xx
3rd byte (MSB of 2nd reg.)	xx
4th byte (LSB of 2nd reg.)	xx
5th byte (MSB of 3rd reg.)	xx
6th byte (LSB of 3rd reg.)	xx
CRC16	--

- Change RTU address / Modbus E01215 and RTU communication speed / Modbus E01216:
 - Connect using a computer (see A51Z1 9 0015A).
 - Type the password 1
 - Go to *Configuration / Modification by variable Number*
 - Chose 01215 or 01216, then select desired value, press SAVE.

Modification by variable nb

Enter the variable number
Like x1xxx :

- Go to *System / save all variables*
- Click on "Flash it!".
- Disconnect UNIGEN, switch power off and then swith it on for new settings to take effect.

3. Settings

UNIGEN includes the following adjustments for calibration and settings:

Settings	Picture	Default value	Description
SYNCHRO Integral SYNCHRO Proportional		6h 6h 	Single turn potentiometers: Integral adjustment of synchronization. Single turn potentiometers: Proportional gain adjustment of synchronization. Synchronization adjustment: <ul style="list-style-type: none"> • Turn P and I fully Counter Clockwise • Turn P potentiometer till the generator is unstable, Come back in CCW to stop the instability. I potentiometer is adjusted with the same procedure.
RAMP TIME		0s	Single turn potentiometer (0...180s). This setting adjusts the time for LOAD and UNLOAD ramps. Duration is for 0...100% kW ramps.
ADJUST kW monitor		None	Multi turn potentiometer (0-100%). Output span adjustment kW (0-5V on terminals 11-12 or 0-20mA/4-20mA on terminals 12-13). See also SW4 configuration.
OFFSET Speed control output		None	Multi turn potentiometer (-10 to +10V _{DC}). Adjustment of the Offset of the speed output. Used to adjust the nominal frequency of the generator (ex: 50.00Hz).
GAIN Speed control output		6h 	Single turn potentiometer (Span from 0 to 10V _{DC}). Span adjustment of the speed control output. Used to adjust the maximum deviation asked by UNIGEN = +/- 3 Hz
OFFSET Voltage control output		None	Multi turn potentiometer (-10 to +10 V _{DC}). Offset adjustment of the voltage control output. Used to adjust the nominal voltage of the alternator (i.e. 400V _{AC})
GAIN Voltage control output		6h 	Single-turn potentiometer (Span from 0 to 10V _{DC}). Span voltage control output. Used to adjust the maximum deviation: = +/- 8% of the nominal voltage.
NOMINAL kW		None	Have to be set during the commissioning. See chapter 6.2.
Switch	<p> CANBUS OFF / 120Ω SPEED REV / DIRECT PLINES / CANBUS SW4 OFF / ON SW5 OFF / ON SW6 OFF / ON SW7 OFF / ON MODBUS OFF / 120Ω </p>	Adjustment of sw1 /sw2 /sw3 /sw4/sw5/sw6 /sw8 depend of settings Default: SW2 ON, Other switches OFF.	Configuration of switches, 2 positions: <u>SW1'terminal resistor of CAN bus'</u> : OFF position resistor not connected; ON position resistor of 120Ω connected. <u>SW2'speed output option'</u> : OFF position reverse speed regulation for GAC speed regulator; ON position direct speed regulation for others regulations. <u>SW3'load sharing mode'</u> : OFF for paralleling lines load sharing; ON position for CAN bus load sharing. Not used on UNIGEN Industrial. <u>SW4'kW monitor output'</u> : OFF for 0-5V _{DC} and 0-20mA; ON for 4-20mA output. <u>SW5'synchronization'</u> : OFF position the relay 'SYNC OK' (terminals 34/35) closes only when conditions are ok and 'SYNC IN' (terminal 3) is connected to the 0V _{DC} ; ON position the relay 'SYNC OK' (terminals 34/35) closes when conditions are ok. <u>SW6'deadbus'</u> : OFF position the relay 'SYNC OK' (terminals 34/35) doesn't close on deadbus condition; ON position the relay 'SYNC OK' (terminals 34/35) closes on deadbus condition. <u>SW7 Speed pot.</u> OFF position, external speed potentiometer is always considered. ON position, external speed potentiometer is considered when generator breaker is open.If not potentiometer value is set to 0. <u>SW8'terminal resistor of Modbus'</u> : OFF position resistor not connected; ON position resistor of 120Ω connected. Not used switch for Industrial Unigen.

4. Display

UNIGEN includes LED to have information feedback.

Led		Description
POWER SUPPLY		Green LED. This LED is ON when DC power supply (12 or 24V _{DC}) is connected.
SYNC IN		This LED is ON when synchronization is required (input 'SYNC IN' closed to the 0V _{DC}) - (SW5 and SW6 configuration).
DROOP		This LED is ON when a droop is required (input 'DROOP' closed to the 0V _{DC}).
BREAKER IN		Green LED. This LED is ON when the genset breaker is closed (input 'BREAKER IN' closed to the 0V _{DC}).
TRIP OUT.		Green LED. This LED is ON when the relay 'TRIP OUT' is closed.
REV KW		Red LED. This LED is ON when the relay 'REV KW' is closed.
START ON LOAD REQUEST		Green LED. This LED is ON when the relay 'START ON LOAD REQUEST' is closed.
SYNC OK		Green LED. This LED is ON when the relay 'SYNC OK' is closed. (SW5 and SW6 configuration).
MAINS PARALLELED		Green LED. This LED is ON when the mains breaker is closed (input 'MAINS PARALLELED' closed to the 0V _{DC} - UNIGEN PLUS only).
COMMAND MODE		Green LED. This LED is ON when a command mode is required (input 'COMMAND MODE' closed to the 0V _{DC} - UNIGEN PLUS only).
CANBUS		Green LED. This LED blinks when load sharing is done through CAN bus. This LED blinks according to the number of UNIGEN modules detected in the CAN bus (Modules with SW3 set to OFF).

5. Terminals

5.1. Terminals description

N° des borniers	Description	Câbles recommandés (mm ² / AWG)	Commentaires
1	POWER SUPPLY +	2.5 / 13	DC Voltage from 9 to 40 V _{DC} , 10 Watts. Twist protection. Note: Terminal 2 must be connected to the 0V terminal of the speed governor with a 4 mm ² wire. Fuse: 5A / 40V _{DC} .
2	POWER SUPPLY -	2.5 / 13	
3	SYNC IN	1 / 17	Not isolated digital input, dry contact to 0V (10kΩ pull-up). This input activates automatic synchronization of the genset (See SW5 and SW6 configuration).
4	DROOP	1 / 17	Not isolated digital input, dry contact to 0V (10kΩ pull-up). This input forces kW and kVAR load sharing in DROOP mode.
5	BREAKER IN	1 / 17	Not isolated digital input, dry contact to 0V (10kΩ pull-up). This input gives the position of generator breaker to the UNIGEN. Use a direct Aux contact of the breaker.
6	UNLOAD	1 / 17	Not isolated digital input, dry contact to 0V (10kΩ pull-up). This input generate an unload ramp generator.
7	TRIP OUT TRIP OUT	1 / 17	Dry contact: normally open. 250V _{AC} , 5A. This output controls the opening of generator breaker at the end of the unload ramp.
8		1 / 17	
9	REV kW REV kW	1 / 17	Dry contact: normally open. 250V _{AC} , 5A. The relay is closed when generator is in reverse power.
10		1 / 17	
11	kW monitor (0 – 5V) +	1.5 / 16	DC analogue output. 0 – 5V (Terminals 11 and 12), 0 – 20mA or 4-20mA (Terminals 12 and 13) (SW4 configuration). This output (voltage and/or current) sends the actual value of kW generator.
12	kW monitor (0V)	0.25 / 23	
13	kW monitor (0 - 20mA) + or (4 - 20mA) +	0.25 / 23	
14	SPEED SET CW +5V	0.25 / 23 *	Analogue input 5kΩ potentiometer or -5/+5V _{DC} between terminal 2(-) and 15(+). Use a shielded wire. This input allows a manual remote control of generator speed. See SW7 configuration.
15	SPEED SET cursor	0.25 / 23 *	
16	SPEED SET CCW -5V	0.25 / 23 *	
17	Generator OUT speed control output	0.25 / 23 *	Analogue output +/-10 V _{DC} . Use a shielded wire. This output controls the speed of generator. Offset and gain potentiometers, this output is compatible with all speed governors of the market. (See SW2 configuration) A51M141 modules: Output PWM 500Hz 5V. See chapter 2.5
18	Generator REF from speed governor speed control output	0.25 / 23 *	
19	Shield	0.25 / 23 *	Terminal to connect the shield of the analogue signals.
20	AVR OUT (+)	0.25 / 23 *	Isolated analogue output +/-10V _{DC} . This output controls alternator voltage. Offset and gain potentiometers, this output is compatible with all AVRs of the market.
21	AVR OUT (-)	0.5 / 20 *	
22	Generator I1+	2.5 / 13	AC current inputs from generator. Current: from 0 to 5A. Max current: 15 A during 10s. Load: 1 VA. The nominal current of the secondary of the current transformers must be as close as possible to 5A.
23	Generator I1-	2.5 / 13	
24	Generator I2 +	2.5 / 13	
25	Generator I2 -	2.5 / 13	
26	Generator I3 +	2.5 / 13	
27	Generator I3 -	2.5 / 13	
28	Générateur L1	1.5 / 16	AC voltage input measurement generator. Line to line voltage from 100 to 500V _{AC} . Frequency: 50 or 60 Hz.
29	Générateur L2	1.5 / 16	
30	Générateur L3	1.5 / 16	

N° des borniers	Description	Câbles recommandés (mm ² / AWG)	Commentaires
31	Générateur Neutre	1.5 / 16	Fuses: 100 mA / 600 V _{AC} . Note: If the neutral input is not connected, UNIGEN will generate an internal virtual neutral point.
32	START ON LOAD REQUEST	1 / 17	Dry contact: Normally open, 250 V _{AC} , 5A. 'START ON LOAD REQUEST' relay is closed when the load request exceeds 80% of the nominal power -> slave generator is to start. 'START ON LOAD REQUEST' relay is opened when the load request is above 20% of the nominal -> Slave generator is to stop.
33		1.5 / 16	
34	SYNC OK	1.5 / 16	Dry contact: normally open, 250 V _{AC} , 5A. 'SYNC OK' relay is closed when the coupling of the generators is safe (See also SW5 and SW6 configuration): - Voltage difference within limits. - Phase difference within limits. - Frequency difference within limits. - Phase sequence - or Deadbus
35		1.5 / 16	
36	SET UNAVAILABLE	1 / 17	Not isolated digital input, dry contact to 0V (10kΩ pull-up). Connect the signal "fault" from the generator.
37	SLAVE INPUT	1 / 17	Not isolated digital input, dry contact to 0V (10kΩ pull-up). Set this UNIGEN as slave for automatic load/unload feature.
38	MAINS PARALLELED (UNIGEN PLUS)	1 / 17	Not isolated digital input, dry contact to 0V (10kΩ pull-up). This input gives the position of mains breaker to the UNIGEN. Use a direct Aux contact of the breaker.
39	Mode COMMAND (UNIGEN PLUS)	1 / 17	Not isolated digital input, dry contact to 0V (10kΩ pull-up). This input forces kW and kVAR load sharing in COMMAND MODE.
40	kW SET CW +5V (Unigen+)	0.25 / 23 *	Analog input 5kΩ potentiometer or 0-5V _{DC} between 42 (-) and 41 (+). Use a shielded wire.
41	kW SET curseur (UNIGEN PLUS)	0.25 / 23 *	
42	kW SET CCW 0V (UNIGEN PLUS)	0.25 / 23 *	
43	Non connecté		
44	Parallel lines High(+)(for Unigen Plus)	2.5 / 13*	0 to 3V. Isolated input. Load sharing and power set level (kW only) when SW3 is set to OFF.
45	Parallel lines low(-)(for Unigen Plus)	2.5 / 13*	Compatibility with other UNIGEN and with analogue load sharing line isolated or not isolated (ex: GCR). Compatibility with Wheatstone bridge.
46	CANBUS+	2.5 / 13*	Isolated input. Load sharing through CAN bus communication (SW3 set to ON for UNIGEN PLUS) - See also SW1 configuration.
47	CANBUS-	2.5 / 13*	
48	SHIELD	0.25 / 23 *	Terminal to connect the shield of the CAN signals.
49	MODBUS A (UNIGEN PLUS)	2.5 / 13 *	19200 bps. Used to communicate with SCADA. MODBUS RTU slave. Read (04 and 03) functions. ('sw8' configuration).
50	MODBUS B (UNIGEN PLUS)	2.5 / 13 *	
51	Bus bar L1	1.5 / 16	AC voltage input measurement bus bar. Line to line voltage from 100 to 500V _{AC} . Frequency: 50 or 60 Hz. Fuses: 100 mA / 600V _{AC} . Note: If the neutral input is not connected, UNIGEN will generate an internal virtual neutral point.
52	Bus bar L2	1.5 / 16	
53	Bus bar L3	1.5 / 16	
54	Bus bar Neutre	1.5 / 16	

Note: * Shielded cable is recommended for these connections. Use 2 or 3 Conductor Foil Shield with drain Wire.

Note: Cable sizes are for guidance only. Cable size should be increased for long cable runs, to overcome possible voltage drop and to increase noise immunity. Only for UNIGEN PLUS.

5.2. Wiring diagram

Terminals of the industrial UNIGEN are all present on UNIGEN *PLUS*.

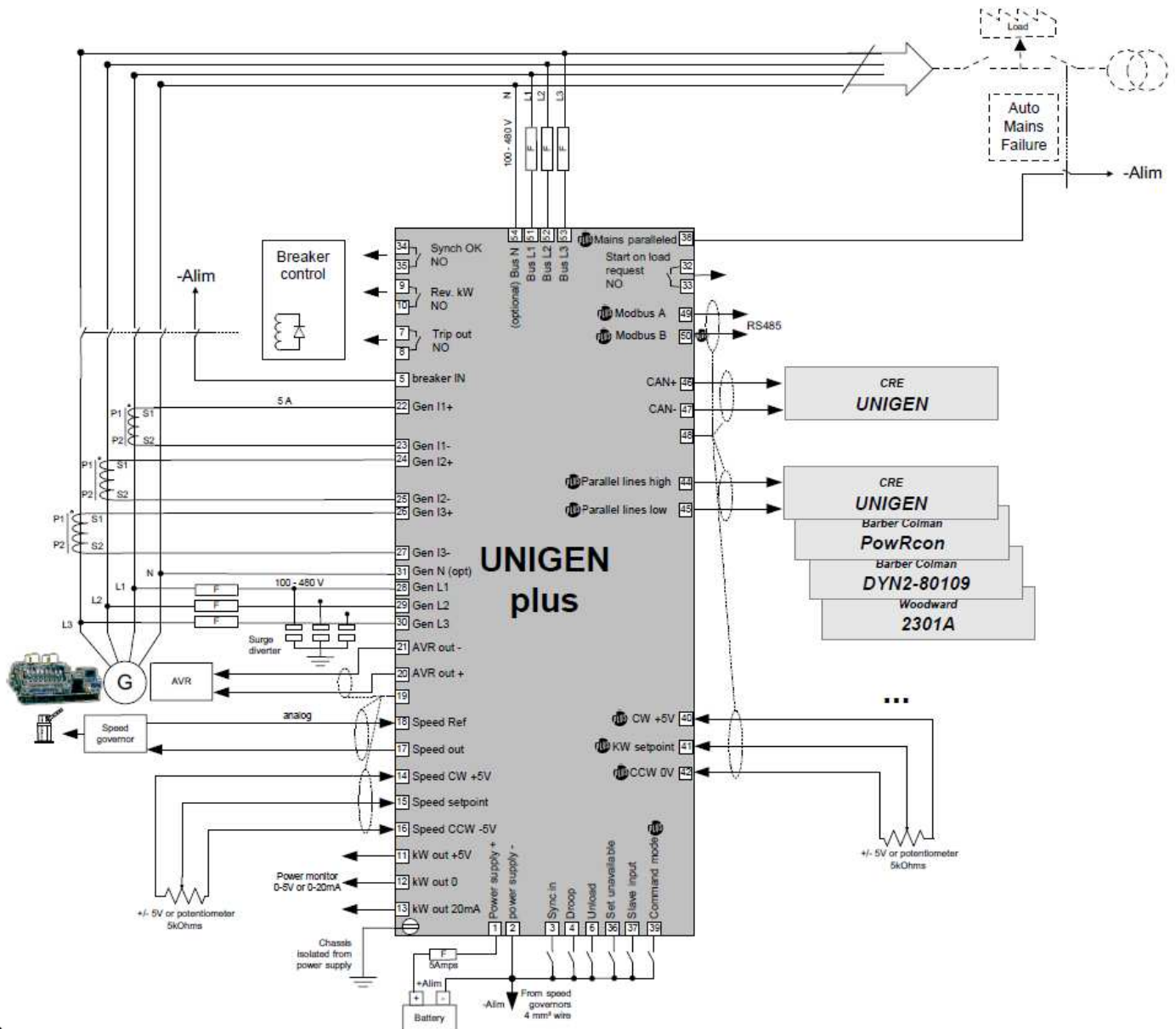

Only for Unigen Plus.

5.3. Connection specifications

- **Power supply:** 9 to 40V_{DC}, <1A with 12 V_{DC} and <500mA with 24V_{DC}.
- **AC voltage inputs:** 100 to 500V_{AC}, 100mA max. The neutral wire can be connected or not.
- **AC currents inputs:** 0 to 5A, 1VA. Each input is isolated from the other ones.
- Possible over-current: 15A during 10s.
- **Frequency measurement:** 45 to 70 Hz – 15 V_{AC} minimum between neutral and line.
- **Digital inputs:** Normally Open, to be connected to 0V (internal pull up of 10kΩ).
- **Relay outputs:** 5A, 230V_{AC} max.
- **Remote speed control input:** 5kΩ potentiometer or +/-5V_{DC}.
- **Remote kW control input for COMMAND mode:** potentiometer (5kΩ) or 0...+5V_{DC}.
- **kW monitor output (0-5V_{DC} or 0-20mA/4-20mA):** the maximum load impedance for the 0-20mA. Or 4-20mA. is 300 Ohms and the minimum load impedance for the 0...+5V_{DC} is 1kΩ.
- **Speed bias output:** The frequency control is made by the adjustable 0-10V_{DC} output. The adjustments are, Offset and Gain potentiometers.
- **Voltage bias output:** The voltage control is done via the AVR. The output is a +/-10V, output with Gain and Offset adjustments.

Terminals: with screws, 2.5 mm².

6. Risk

6.1. Caution

6.1.1. Grounding:

The grounding of the chassis of UNIGEN must be done with the M5 screw. Use a 4mm² wire to connect to earth, this cable should be as short as possible.



6.1.2 Wiring rules:

The cables with high voltage (400V_{AC}) and/or high current (5A) must be separated from the command cables. All the command and digital inputs / outputs can be in the same cable path.

If you have to cross the command/DC cables with the 400V/5A cables, it is recommended to cross with a right angle. The grounding must be done in a proper way to avoid personal injuries and for a reduction of EMC.

6.1.3 Vibrations:

In case of heavy vibrations, UNIGEN should be mounted using AV Mounts.

6.2. Power plant start-up/Commissioning

Caution: before starting the generating sets, please read the following part.

This is a standard commissioning for a simple power plant. If you use only this procedure, it can't engage our responsibility.

Before commissioning (before going on site)

Check of schematics

How?

- Be sure you have the latest power plant schematics.

Why?

- To be sure the wires will be present on site (Can bus connector, shielded wires...).

What?

- 0 Volt wiring.
- Shields.
- Speed governor / UNIGEN Interface.
- Automatic Voltage Regulator / UNIGEN Interface (droop current transformer must be removed).
- CAN bus.
- Paralleled lines.

During commissioning

Start in safe condition

How?

- Generator breaker output locked in open position.
- Disconnect the wires between UNIGEN (terminals 17/18) and the speed governor.
- Disconnect the wires between UNIGEN (terminals 20/21) and the AVR.
- Ask the technician who had wired the power plant to lock the generator breaker open.
- Battery negative of each UNIGEN power supply (terminal 2) must be connected to each other UNIGEN and to the 0V of the speed governor.
- Disconnect the wires of the relay 'SYNC OK' (terminals 34/35) of the UNIGEN.

Why?

- To be sure not to drive a false paralleling during the beginning of commissioning.

Switches configuration

How?

- Put switches in OFF/ON position before start the engine, see chapter 3 'Settings' for more details.

Why?

- To configure several important functions of the UNIGEN.

Interface UNIGEN / Speed governor

Interface UNIGEN / Auto Voltage Regulator

How?

- Start the engine.
- Adjust the nominal speed and voltage, for example 50.00Hz & 400V_{AC}, on the speed/voltage regulator. If a trim pot is present on the AVR, adjust it to get +/-8% (see AVR manufacturer doc).
- Stop the engine.
- Remove the cover of the UNIGEN if necessary.
- Connect only the ref wire (terminal 18) to the speed governor "speed ref output".

➤ Speed setting :

- Start the engine.
- Adjust Speed gain RV10 full CCW on the UNIGEN.
- Measure the voltage between Ref and remote voltage input on speed regulator side.
- Adjust UNIGEN output voltage (terminals 17/18) adjusting the offset RV9 to have the same voltage than measurement of previous point.
- Connect the control wire (terminal 17).
- Close the 'SYNC IN' input (connect terminal 3 to 0V). UNIGEN is trying to synchronize on a dead bus (00.00Hz).
- Adjust the speed gain RV10 to have 48.00Hz.
- Open the 'SYNC IN' input.
- Stop the generator.

- Voltage setting :
 - Adjust AVR Offset RV11 & Gain RV112 full CCW on the UNIGEN.
 - Connect AVR outputs (terminals 20/21) to AVR.
 - Adjust voltage offset RV11 to have $400V_{AC}$.
 - Close 'SYNC IN' input (Terminal 3 to 0 volts).
 - Adjust AVR Gain RV12 to reach $370V_{AC}$

Check the control of the breaker on dead bus

- Be sure there is no critical load connected on bus bar.
- Close the breaker and verify that the breaker feedback (terminal 5) is closed (the 'BREAKER IN' LED should light on).
- Open the breaker and verify that the breaker feedback (terminal 5) is opened (LED not lit).

Adjustment of the nominal power

- For the Industrial UNIGEN:
 - Set the kW monitor output in 0-5V: switch SW4 to OFF position.
 - Put in full CW the multi turn potentiometer *ADJUST* RV7.
 - Close the circuit breaker of the generator. The 'BREAKER IN' led must light (terminal 5).
 - Apply 100% of load on the generating set (with bench load for example).
 - Adjust 'NOMINAL kW' potentiometer RV13 to reach $7.45V_{DC}$ between terminals 11(+) and 12(-) of the UNIGEN.
 - Open the circuit breaker of the generator.
 - Set switch SW4 as desired depending on your application.

- UNIGEN *PLUS* (Generating set below 200kW):
 On GE with a nominal power below 200kW, adjustment of *NOMINAL kW* potentiometer RV13 may be hard to find. To adjust this setting more easily it may be helpful to decrease UNIGEN *PLUS* internal CT ratios (Factory set to 1000). This can be done by lowering value of variables E11002, E11003 and E11004 (e.g. set them to 200):

- Connect to UNIGEN *PLUS* internal Website using a computer (see document A51Z1 9 0015A).
- Type in password "1".
- Go to **Configuration/Modification by variable nb** page.

Modification by variable nb

Enter the variable number
 Like x1xxx :

- Enter the number of the variable to modify (at first "11002") and validate.
 - Enter the new desired value and press SAVE button.
 - Repeat these steps for variables E11003 and E11004.
 - Go to page **System/save all variables**.
 - Click on "Flash it!".
 - Disconnect UNIGEN, switch power off and then switch it on again for new settings to take effect.
 - Finally, adjust the nominal power potentiometer as described below for engines above 200kW.
 - UNIGEN *PLUS* (Generating set with nominal power between 200kW and 4000kW):
 - Switch SW3 to OFF position.
 - Paralleling lines are not connected on terminals 44 and 45.
 - Close the circuit breaker of the generator. The 'BREAKER IN' led must light (terminal 5).
 - Apply 100% of load on the generating set (with bench load for example).
 - **Adjust** 'NOMINAL kW' potentiometer RV13 to obtain 3V on parallel lines (terminal 44 & 45).
- Open the circuit breaker of the generator.

Check wiring of current

- Put load.
- Measure the voltage between terminals 11 and 12.
- Shunt the phase 1 current directly of the secondary of the current transformer (CT).
- Measure the voltage between terminals 11 and 12. Check that this voltage decrease of 1/3 that before.
- Do the same test for phases 2 and 3 (don't forget to remove the shunt of each phase after test).

- Switch SW3 as desired depending on your application.

Check synchronization

- Close the breaker to have voltage on the bus bar (mains or other generator).
- Lock the engine breaker in open position.
- Start the engine to check the synchronization.
- Close 'SYNC IN' input (terminal 3 to 0VDC).
- Adjust P (RV15) & I (RV1) potentiometers of synchronization to have a response time of 4 or 5 seconds to get the 'SYNC OK' signal (terminals 34/35) the relay closes.
- With a voltmeter check on both sides of the breaker if the voltage is <20VAC on each phases.
- With the voltmeter check also that there is 400VAC between phase 1 of the engine and phase 2 of the bus bar (crossed monitoring).
- In this test we don't close the breaker.
- If the test is OK, connect the wires of the relay 'SYNC OK' (terminals 34/35) of the UNIGEN.

Load sharing / kW regulation

- Regarding the application check the stability of kW and kVAR regulation.
- Open Breaker.
- Stop engines.

Environment

- **Operational temperature:** 0 to + 70°C.
- **Storage temperature:** -30 to +70°C.
- **Humidity:** 5 to 95%. The PCB is tropicalized to be used in humid climate areas. Protection IP20.
- **Size:** 275x200x26mm.
- **Mounting:** Can be placed in all positions.
- **Weight:** 1.5Kg.
- **CE directives:**
 - Generic emission standard: EN 50081-2, EN 50082-2.
 - Generic immunity standard: EN 61000-6-2.
 - Low voltage directive: 73/23EEC.

Dimensions

